

SHORT WHEELBASE

FIGHTER FM1628

4x2 • MANUAL



GVM:
16,000kg



Power / Torque:
207kW / 802Nm



Wheelbase:
4,280mm (H)

- 30,000km service intervals
- 6spd or 9spd transmission
- Isringhausen driver's seat
- 6.5T front axle

SPECIFICATIONS - FIGHTER FM1628 SWB

MODEL

4x2 FM1628	6 SP.	MAN	STEEL SUSP.	FM65FH2RFAH
4x2 FM1628	9 SP.	MAN	STEEL SUSP.	FM65FH2RFAK

WHEELBASE (mm)

4,280 (H)
4,280 (H)

GVM (kg) (optional)

16,000 (12,000)
16,000 (12,000)

GCM (kg)

25,000
32,000

ENGINE

Engine Version	FUSO 6M60-9AT2 Diesel
Configuration	6 Cyl. In-line OHC, 4-Valve
Type	Variable Geometry Turbo Charged Air to Air Intercooler
Displacement	7.5 litre (7545cc)
Power ECE Nett	199kW @ 2500rpm
Torque ECE Nett	785Nm @ 1100-2400rpm
Power (JIS Gross)*	207kW (281ps) @ 2500rpm
Torque (JIS Gross)*	802Nm(592lbft) @ 1100-2400rpm
Maximum Engine Speed (rpm)	2900
Compression Ratio	16.0:1
Cooling System/Oil Cooler	Water cooled with Viscous fan, 23.0L capacity. Engine oil cooler
Air Cleaner	Paper Element Type with Restrictor Indicator. Vertical Intake Mounted on Clean Air Side (RH)
Cold Start Preheat	Standard
Emission Control	Selective Catalytic Reduction (SCR) after-treatment system (BlueTec), Positive Crankcase Ventilation (PCV)
Emission Level	Euro 5 (ADR 80/03)

*Calculated

6M60-9AT2

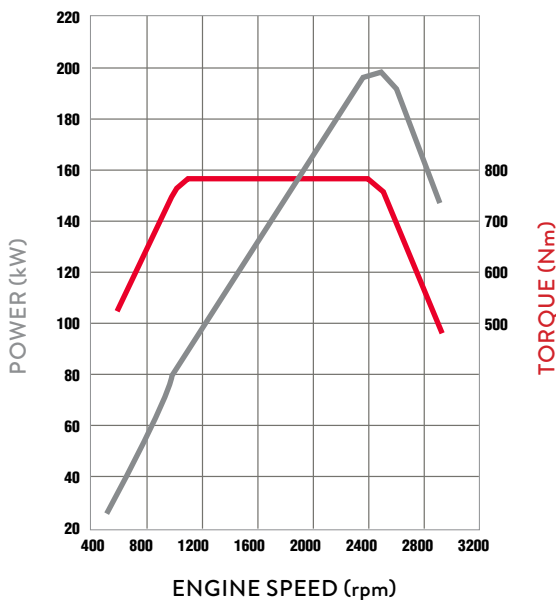

FUEL

Injection System	DENSO Common Rail System Electronically Controlled Direct Injection
Tank Type	Rectangular Alloy Tank with Locking Cap
Fuel Capacity (L)	300
AdBlue Exhaust Fluid Capacity (L)	40

ELECTRICAL

Voltage	24V Negative Earth
Alternator Capacity	24V-80 amp
Battery Specification	Heavy Duty 2 x 12V, 100Ah/20hr
Headlamp Type	Halogen 2 x 70W/75W

CLUTCH

	Manual
Clutch Model	FUSO C7M38
Type	Single Plate Cerametallic 380mm
Operation/Specification	Air Assisted Hydraulic

TRANSMISSION

	6 Speed	9 Speed
Version	FUSO Manual M070S6-OD	Eaton Manual ES-11109 (Fuso Code M060S9)
Type/Speeds	6 with Air Assisted Gearshift	9 Speed
Features	Synchromesh 2nd-6th	Synchromesh 1L-4H
Ratios	1st: 6.807 2nd: 4.172 3rd: 2.396 4th: 1.504 5th: 1.000 6th: 0.774 Rev. 6.807	Low Range Low: 12.64 1st: 8.81 2nd: 6.55 3rd: 4.77 4th: 3.55 High Range 1st: 2.48 2nd: 1.85 3rd: 1.34 4th: 1.00 Rev: 13.21
PTO Opening	LH Side	LH Side and Rear

PROPELLER SHAFT

	6 Speed	9 Speed
Type	P10	P12
Universal Joint	Needle Roller	

FRONT AXLE

Axle	FUSO F650T "I" Beam
Design Capacity (kg)	6,500
Max Operating Capacity (kg)	6,500

FRONT SUSPENSION

Type	Taper Leaf spring with Double Acting Shock Absorbers
Size (mm)	1,400 x 80

REAR AXLE

	6 Speed	9 Speed
Axle	FUSO D8H Full Floating Hypoid	FUSO D10H Full Floating Hypoid
Design Capacity (kg)	10,200	10,800
Max Operating Capacity (kg)	10,000	10,000
Ratio	5.142:1	4.625:1

SPECIFICATIONS - FIGHTER FM1628 SWB

REAR SUSPENSION

Type	Steel Suspension
Details	Multi Leaf spring
Size Main Leaves (mm)	1,400 x 80
Size Helper Leaves (mm)	960 x 80

STEERING

Power Assisted	Tilt/Telescopic Adjustable Steering Wheel
----------------	---

BRAKES

Type	Full Air, Dual Circuit, FUSO Taper Roller, Automatic Brake adjustment, ABS
ASR (Traction Control)	Yes
Size Front / Rear (mm)	410 x 150 / 410 x 200
Park Brake	Rear Wheel Spring Actuated
Auxiliary	Exhaust Brake
Compressor	Water Cooled, 340cc Single Cylinder with air dryer

WHEELS AND TYRES

Wheel Type	7, Single Piece Steel Disc
Wheel Size	22.5 x 8.25DC-165-13t
Wheel Stud Pattern	10 stud 335mm PCD
Tyre Size All	11R22.5
Spare Tyre Carrier	Provided

CHASSIS

Type	Reinforced Parallel Channel
Size (mm)	280 x 90 x 8.0
Width (mm)	841

Refer to the bodybuilders guidelines on the Fuso website (www.fuso.co.nz) before mounting a body or modifying the chassis

INSTRUMENTS

Gauges	Speedometer with Odometer Tachometer Air Pressure (2) Fuel Level Water Temperature
Colour Information Display	Fuel Consumption Service Indicators Hour Meter and Tripmeter

STANDARD FEATURES

Airbag	Driver's Air Bag and Seat Belt Pre-tensioner
Hill Start System	Yes
Cab Cooling and Heating	Air Conditioner / Heater / Demister

KERB WEIGHTS AND MAX AXLE LOADS (kg)

Model		Vehicle Ratings**		Max Axle Loadings**		Kerb Weights*		
		GVM	GCM	Front	Rear	Front	Rear	Total
4x2 FM1628 6 Sp. Man Steel Susp.	FM65FH2RFAH	16,000	25,000	6,500	10,000	2,840	1,870	4,710
4x2 FM1628 9 Sp. Man Steel Susp.	FM65FH2RFAK	16,000	32,000	6,500	10,000	2,925	1,925	4,850
4x2 FM1228 6 Sp. Man Steel Susp.	FM65FH2RFAH(D)	12,000	25,000	6,500	10,000	2,840	1,870	4,710
4x2 FM1228 9 Sp. Man Steel Susp.	FM65FH2RFAK(D)	12,000	32,000	6,500	10,000	2,925	1,925	4,850

* Weights (est.) includes 10L fuel and spare wheel and are subject to 2.5% variation (+/-)

** Vehicle ratings and max axle loadings may be limited by local regulations.

STANDARD FEATURES

Accessory Power	24V Accessory Power Outlet / Cigar Lighter
Driving	Keyless Central Locking Electric Windows Cruise Control LH Transom Window AM/FM CD + USB + AUX + Bluetooth Hands Free Cup Holders (4) Rear Quarter Glass Fluorescent Cabin Lamp and Interior Reading Lamps Engine Idle Speed Control
Storage	Centre Seat Storage Console Rear Bunk Storage Pocket Dash Storage Tray 2 DIN Glove Compartment 1 Single and 1 Double DIN Slot for Accessor Overhead Storage Pocket with Lid RH Door Storage Pocket
Cab: External	Roof Mounting Points (max. static load 70kg) Front End-Outline Marker Lamps
Chassis	Chassis Mounted Tool Box Reverse Warning Buzzer

CAB FEATURES

Type	All Steel Forward Control Manual Tilt 44 deg.
Mounting	Hydroelastic Susp. 4 Point
Colour	Natural White (W31)
Interior	Fully Trimmed
Windscreen	Laminated Tinted
Windscreen Wipers	2 Speed + Intermittent Cycle with Integrated Washer Nozzles
Door	90 degree Opening Angle
Rear Vision Mirrors	Remote Control / Heated with Convex Spotter (Both Sides)
Seating Capacity	3
Seat Belts	Lap Sash Belts for Outside Seating Positions Lap Belt for Centre Seat
Seat (driver)	ISRI Air Suspension with Auto Levelling, Height, Tilt and Dampening Adjustment Integral Headrest and Fabric Trim
Seats (passenger)	Centre: Low Back with Fabric Trim and Forward Folding Far Passenger: Fixed Base with Reclining Seat Back, Integral Headrest and Fabric Trim

SERVICE INTERVALS

Please contact your nearest Fuso dealer for details

WARRANTY

36 months or 200,000km (whichever occurs sooner)
Subject to terms and conditions in the Fuso Warranty Booklet

SPECIFICATIONS - FIGHTER FM1628 SWB

PERFORMANCE

	6 Speed	9 Speed
Turning Circle (kerb to kerb - metres)	14.6	14.6
Electronically Speed Limited to:	100km/hr	100km/hr
Engine Speed (rpm) at 90km/hr (top gear)	2430	2185
Gradeability at Rated GVM (theoretical)*	37%	54%
Gradeability at Rated GCM (theoretical)*	22%	24%
Note	*This is theoretical performance only. Actual performance may vary under different conditions	

DIMENSIONS (MM)

	H Wheelbase
Wheelbase	4,280
Length Overall	7,455
Height Overall	2,680
Width Overall	2,470
Width Rear Axle	2,470
Width Front Track	1,925
Width Rear Track	1,850
Width Frame	841
Height Frame at Rear Axle	1,075

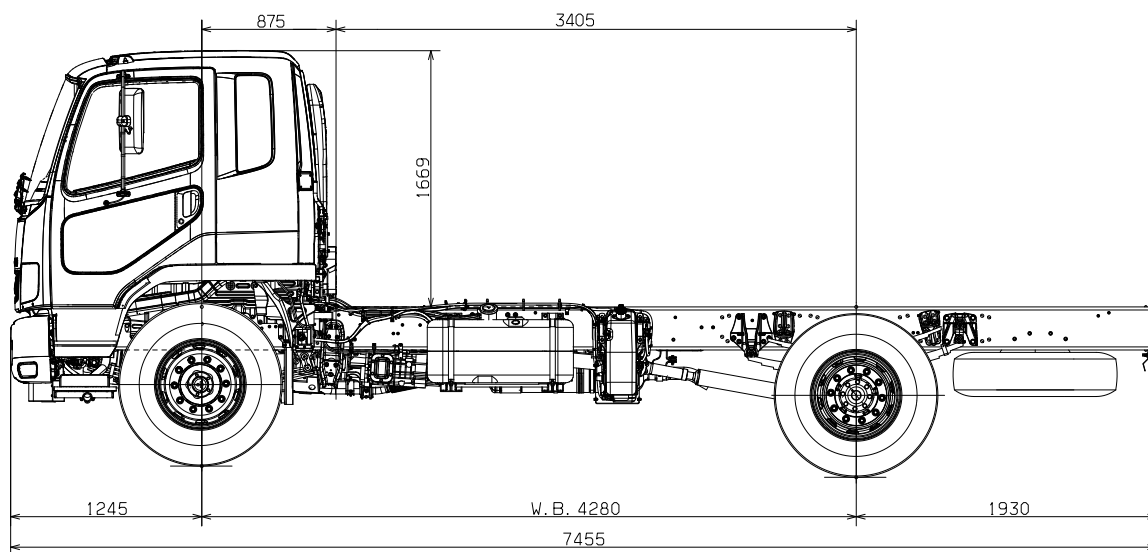

FIGHTER FM1628 – 'H' WHEELBASE

1000
UNIT: mm 20mm=1m

Scale = 1:50 (20mm = 1 metre). This scale is accurate when used on the original spec sheet, be aware that enlarging these illustrations can alter the scale and cause incorrect measurements. Fuso New Zealand and its authorised dealers always recommend customers seek professional advice from independent sources before commencing any engineering activities.

A policy of continual improvement means that specifications detailed in this brochure are subject to change without notice. Contact your authorised Fuso dealer to confirm current specifications. Fuso is a registered trademark of Mitsubishi Fuso Truck & Bus Corporation. Copyright © Fuso NZ (2017)